

Ender - 3

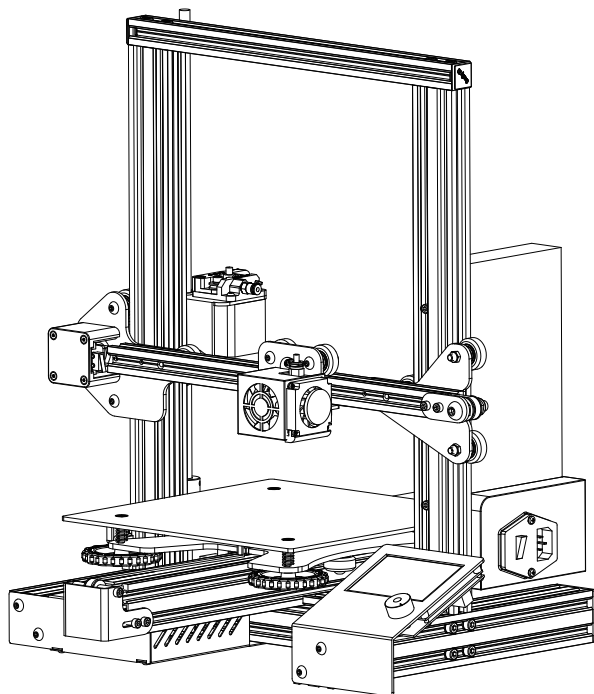

- >Příručka pro 3D Tiskárnu
- >Zvolte správné zdrojové napětí odpovídající vaší místní síti (**230V / 115V**)
- >Kvůli různým zdokonalením v oblasti hardwaru i softwaru a rozdílnosti modelů, nemusí být novější revize v této příručce uvedeny
- >Používejte napájecí kabel s tříhrotovým konektorem
- >Detailnější informace naleznete na paměťové kartě

Seznam č.1

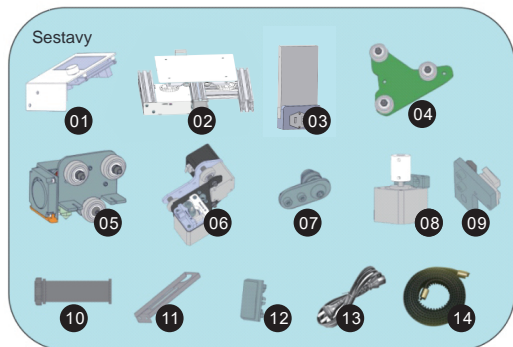

Seznam č.2

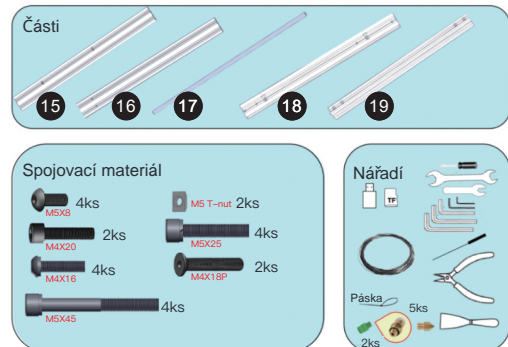

Krok č.1

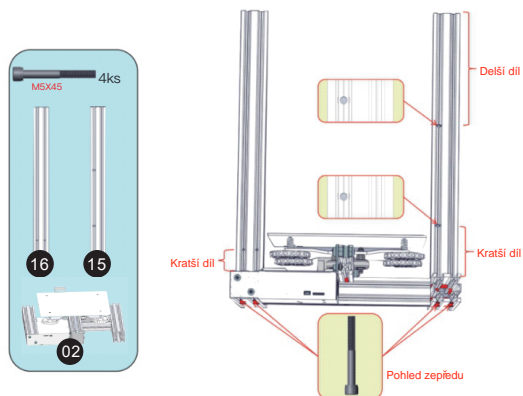

Krok č.2

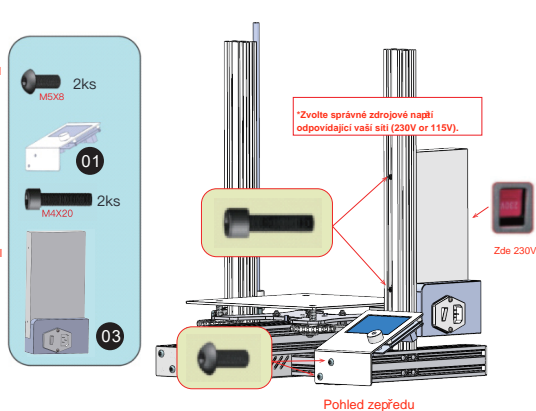

Krok č.3

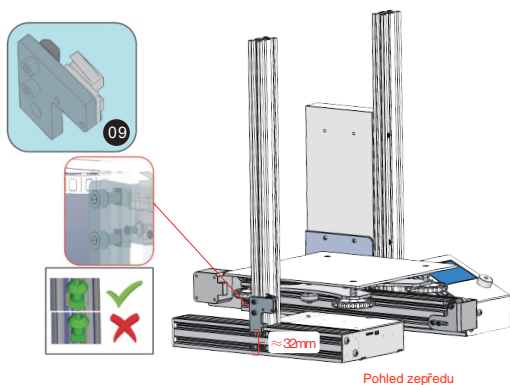

Krok č.4

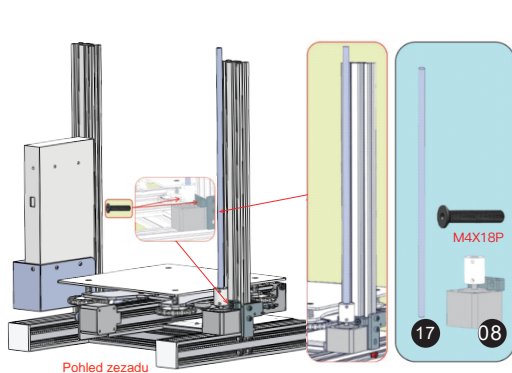

Krok č.5

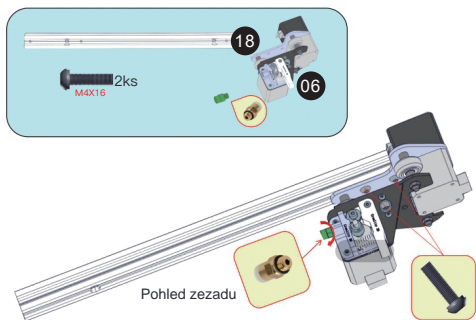

Krok č.6

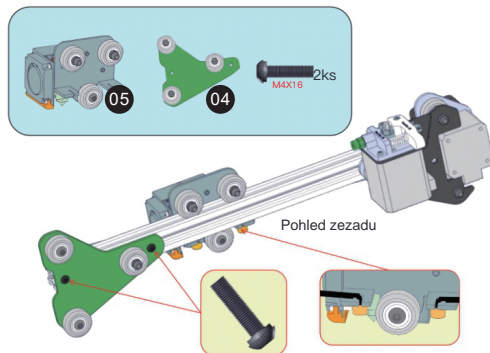

Krok č.7

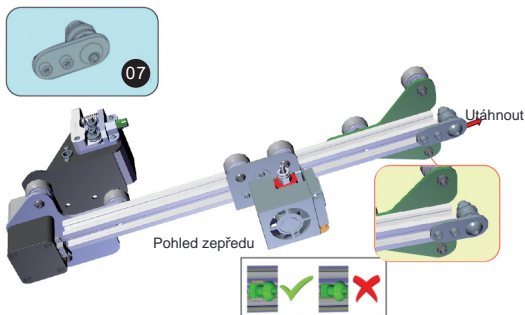

Krok č.8

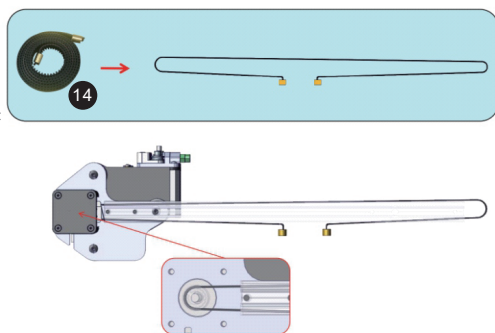

Krok č.9

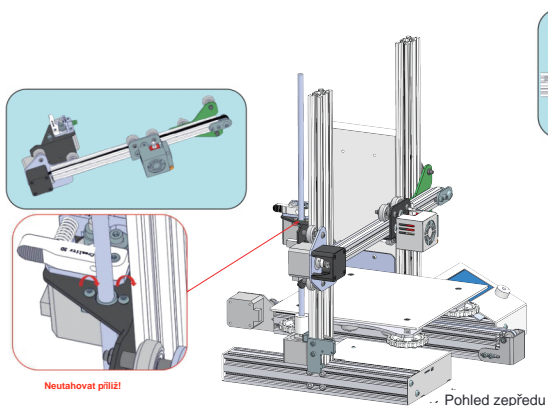

Krok č.10

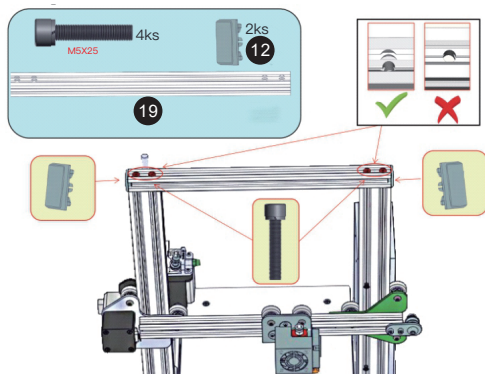

Krok č.11

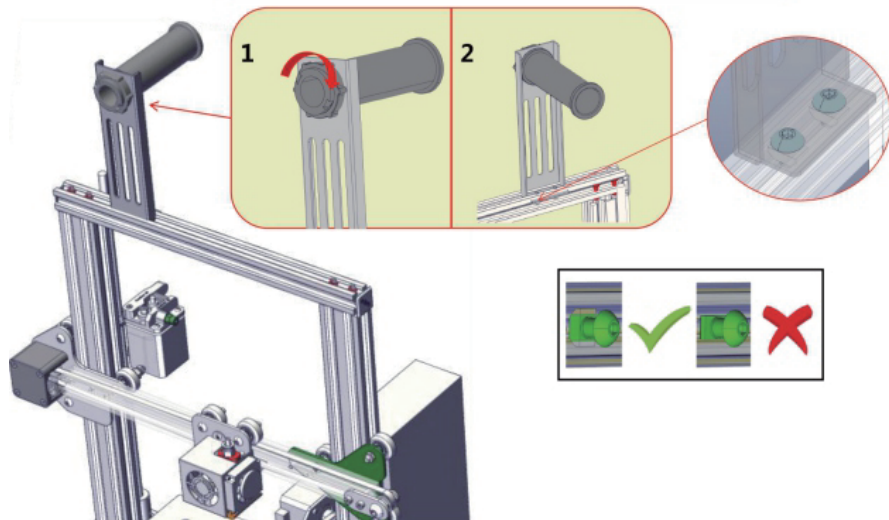

Krok č.12

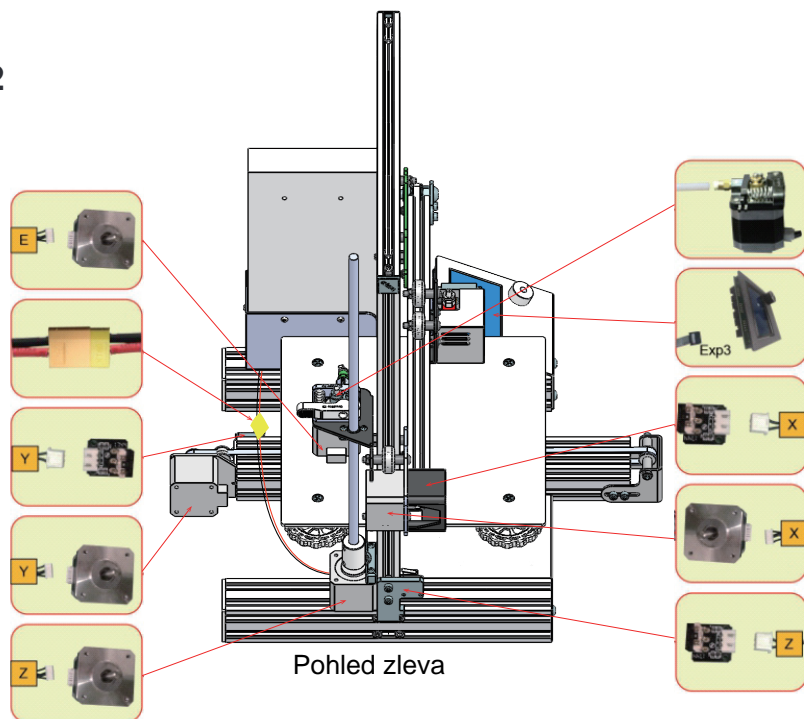

Due to the differences between different machine models, the physical objects and the final images can differ. The final explanation rights shall be reserved by Shenzhen Creality 3D Technology Co., Ltd.

因每款机型不同,实物与图可能有所差异,请以实物为准,最终解释归深圳市创想三维科技有限公司所有。

Překlad: Creality tým

<https://www.crealitystore.cz/>

KONTAKTUJTE NÁS: Adresa: Vodní 5b, Blansko 678 01

Telefon: +420 704 600 497

Facebook: Creality Store

E-mail: obchod@crealitystore.cz



SHENZHEN CREALITY 3D TECHNOLOGY CO.,LTD.

11F & Room 1201,Block 3,,JinChengYuan,Tongsheng Community,
Dalang,Longhua District,Shenzhen,China,518109

Official Website: www.creality.com

Tel: +86 755-8523 4565

E-mail: info@creality.com cs@creality.com



深圳市创想三维科技有限公司

深圳市龙华区大浪街道同胜社区金城工业园第三栋1201、11层

公司网站: www.cxsw3d.com

服务热线: 400 6133 882

0755-8523 4565

